

NOTICE - PROPRIETARY INFORMATION
 THE DESIGN AND RELATED INFORMATION CONTAINED HEREIN
 IS THE SOLE PROPERTY OF COFAN INC. THE DISCLOSURE
 OF THIS INFORMATION DOES NOT CONSTITUTE THE RELEASE OF
 ANY PROPRIETARY RIGHTS THEREIN. PERMISSION TO REPRODUCE
 THIS INFORMATION OR THE PRODUCTS DISCLOSED HEREIN
 MUST BE OBTAINED IN WRITING FROM COFAN INC.

REVISION HISTORY					
REV	DESCRIPTION	DRWN	CHK'D	APPVD	DATE
---	SEE SHEET 1	---	---	---	---

- NOTES:**
1. MATERIAL: ALUMINUM 6063-T5.
 2. FINISH: BLACK ANODIZE
 3. PART SHALL BE FREE OF SHARP CORNERS/EDGES/BURRS.
 4. Δ IS CRITICAL INSPECTION POINT. NUMBERING IN TRIANGLE IS TO BE USED FOR CROSS REFERENCE OF INSPECTION REPORT TO DRAWING DIMENSION OR FEATURE.
 5. PART WEIGHT: 34.46g/PCS.

RoHS
 Compliant
 2002/95/EC

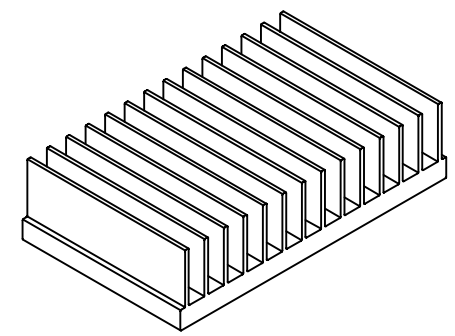
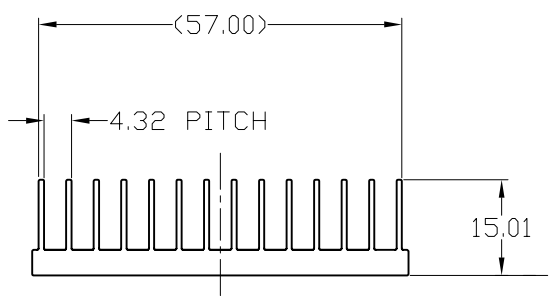
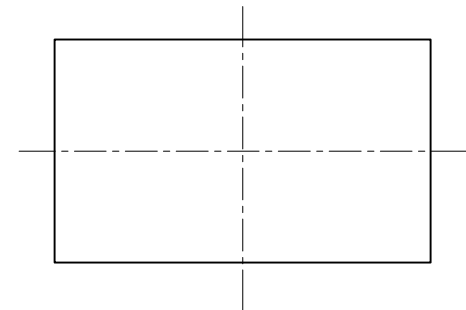
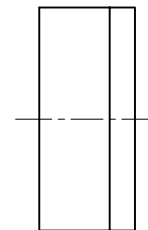
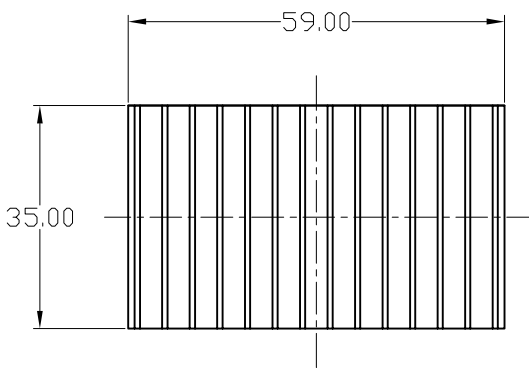

DO NOT SCALE DRAWING
 UNLESS OTHERWISE SPECIFIED
 DIMENSIONS ARE IN MILLIMETRE
 TOLERANCES ARE:
 1 PLACE .X ±
 2 PLACE .XX ± 0.13
 3 PLACE .XXX ±
 ANGLES EXCEPT 90° ± 1°
 MAXIMUM SURFACE ROUGHNESS 125 $\sqrt{\text{ }}$

MATERIAL: 1	CUSTOMER DRAWING NUMBER: -----	COFAN USA 1400 FULTON PL. UNIT A FREMONT CA 94539		
FINISH: 2	CUSTOMER PART NUMBER: -----	NAME: HEAT SINK 59 x 35 x 15mm		
DRAWN BY: Long	COFAN DRAWING NUMBER: 20-2027	SCALE: 1 : 1	CUS REV: 01	COF REV: 01
APPR BY:	COFAN PART NUMBER: 20-2027	SHEET: 1 OF 1	DATE DRAWN: Jun-19-2006	