

NOTICE - PROPRIETARY INFORMATION  
 THE DESIGN AND RELATED INFORMATION CONTAINED HEREIN  
 IS THE SOLE PROPERTY OF COFAN INC. THE DISCLOSURE  
 OF THIS INFORMATION DOES NOT CONSTITUTE THE RELEASE OF  
 ANY PROPRIETARY RIGHTS THEREIN. PERMISSION TO REPRODUCE  
 THIS INFORMATION OR THE PRODUCTS DISCLOSED HEREIN  
 MUST BE OBTAINED IN WRITING FROM COFAN INC.

REVISION HISTORY					
REV	DESCRIPTION	DRWN	CHK'D	APPVD	DATE

- NOTES :
- 1.MATERIAL:C1006 BRIGHT BASIC WIRE.
  - 2.FINISH:BRIGHT NICKEL CHROME.RoHS COMPLIANT
  - (1)RINGS ARE Ø1.6mm.  
(2)RIBS ARE Ø1.6mm.
  - 4.WELD JOINTS TO WITHSTAND 88 LBS PULL FORCE.
  - 5.SPACING BETWEEN RINGS TO BE EQUIDISTANT.
  - 6.GENERAL TOLERANCE UNLESS NOTED:±0.5mm.
  - 7.PART MEETS Ø6.35mmPLUG GAUGE TEST.
  - 8.UNIT :mm.

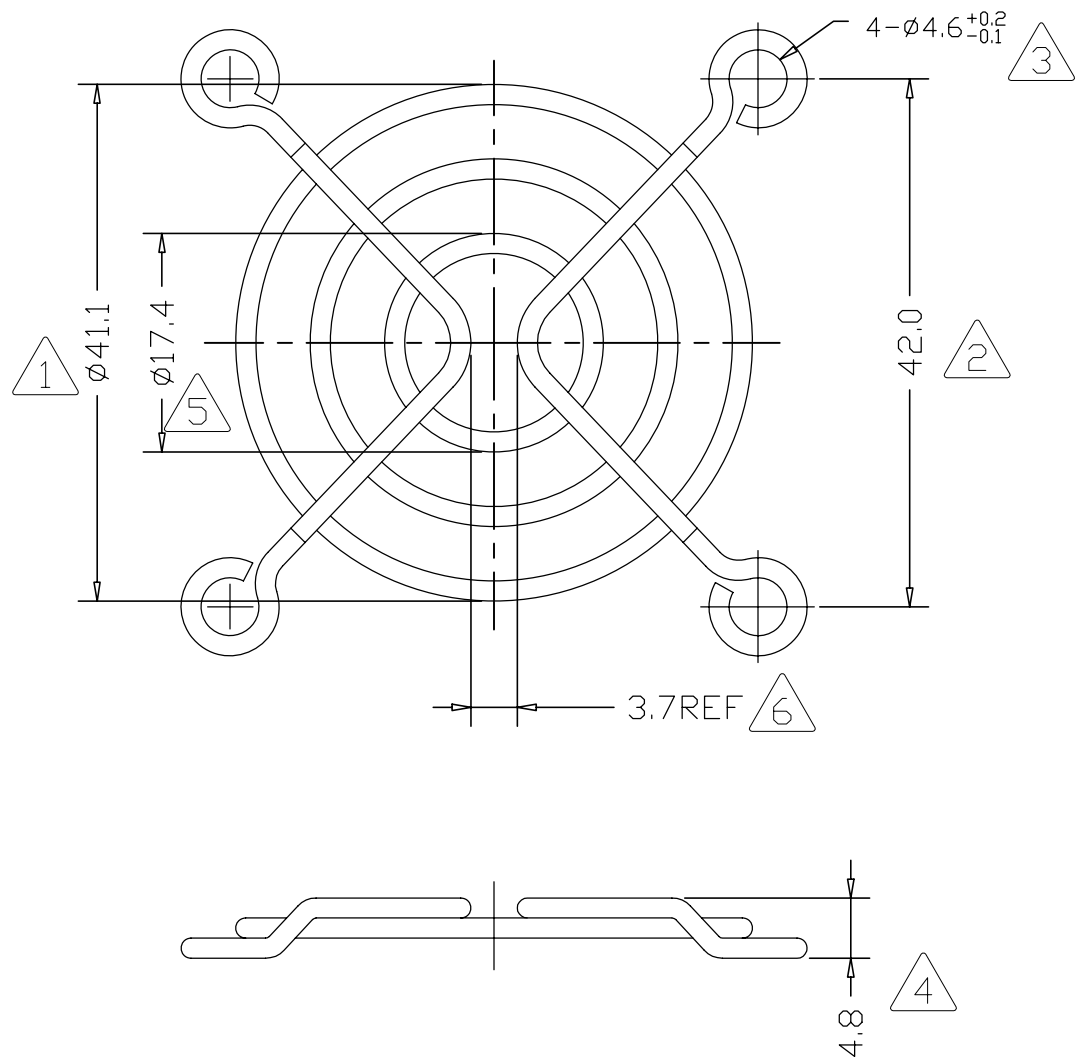

<b>DO NOT SCALE DRAWING</b> <small>UNLESS OTHERWISE SPECIFIED          DIMENSIONS ARE IN MILLIMETRE          TOLERANCES ARE:</small> 1 PLACE .X ± 0.5 2 PLACE .XX ± 0.25 3 PLACE .XXX ± 0.13 ANGLES EXCEPT 90° ± 0.5° MAXIMUM SURFACE ROUGHNESS 3.2√	MATERIAL: 1	CUSTOMER DRAWING NUMBER: ---	 <small>46177 WARM SPRINGS BLVD FREMONT CA 94539</small>		
	FINISH: 2	CUSTOMER PART NUMBER: ---	NAME: 50mm FAN GUARD, 42mm SPACING		
	DRAWN BY: <i>Ajie</i>	COFAN DRAWING NUMBER: 54-1014	SCALE: 1:1	CUS REV: 01	COF REV: 01
	APPR BY:	COFAN PART NUMBER: 54-1014	SHEET: 1 OF 1	DATE DRAWN: Oct-27-2005	