

NOTICE - PROPRIETARY INFORMATION
 THE DESIGN AND RELATED INFORMATION CONTAINED HEREIN
 IS THE SOLE PROPERTY OF COFAN INC. THE DISCLOSURE
 OF THIS INFORMATION DOES NOT CONSTITUTE THE RELEASE OF
 ANY PROPRIETARY RIGHTS THEREIN. PERMISSION TO REPRODUCE
 THIS INFORMATION OR THE PRODUCTS DISCLOSED HEREIN
 MUST BE OBTAINED IN WRITING FROM COFAN INC.

REVISION HISTORY					
REV	DESCRIPTION	DRWN	CHK'D	APPVD	DATE
---	SEE SHEET 1	---	---	---	---

A	B	C	D	E	F	G
42±0.5	40±0.3	5.0±0.2	17.5±0.5	1.6±0.2	4.5±0.6	5.0±0.5

COFAN 50MM FAN GUARD
 COFAN PART # FG50CP

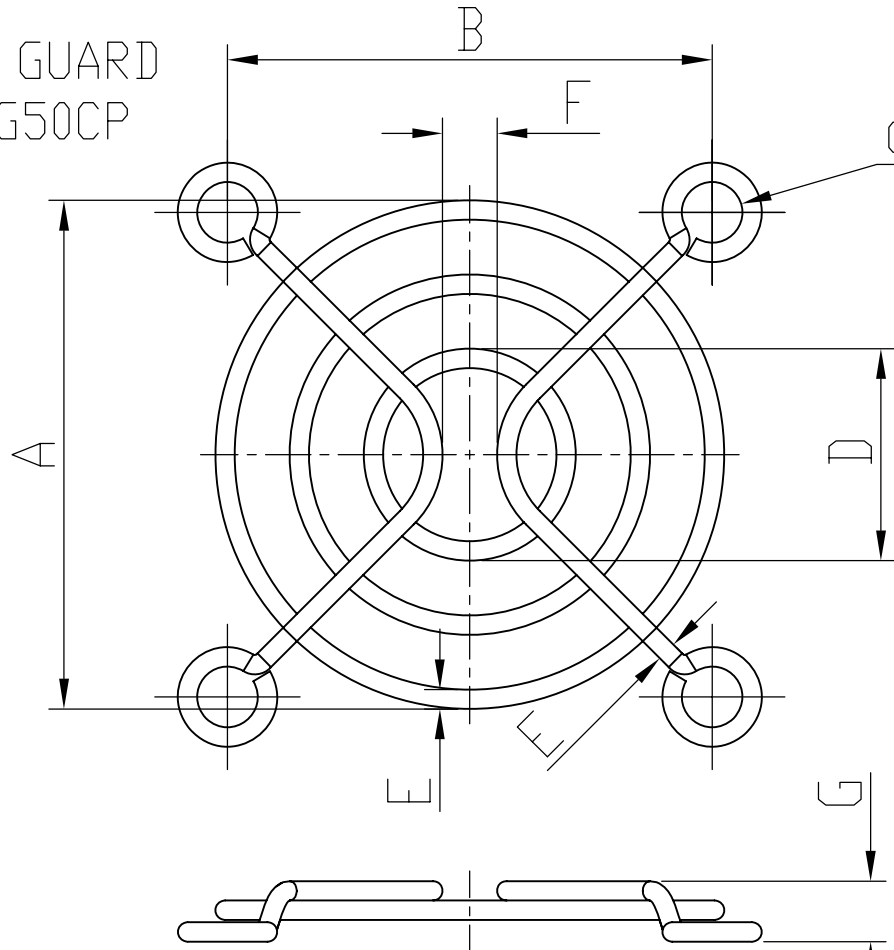

DO NOT SCALE DRAWING UNLESS OTHERWISE SPECIFIED DIMENSIONS ARE IN MILLIMETRE TOLERANCES ARE: 1 0-6 ± 0.1 2 6-12 ± 0.15 3 12+ ± 0.2 ANGLES EXCEPT 90° ± 2° MAXIMUM SURFACE ROUGHNESS √	MATERIAL: MG	CUSTOMER DRAWING NUMBER: ---	Cofan USA 1400 FULTON PL. UNIT A FREMONT CA 94539		
	FINISH: CHROMEPLATED	CUSTOMER PART NUMBER: ---	NAME: 50mm FINGER GUARD		
	DRAWN BY: ZHENG	COFAN DRAWING NUMBER: ---	SCALE: 2:1	CUS REV: 01	COF REV: 01
	APPR BY:	COFAN PART NUMBER: FG50CP	SHEET: 1 OF 1	DATE DRAWN: 02-18-2004	