

NOTICE - PROPRIETARY INFORMATION  
 THE DESIGN AND RELATED INFORMATION CONTAINED HEREIN  
 IS THE SOLE PROPERTY OF COFAN INC. THE DISCLOSURE  
 OF THIS INFORMATION DOES NOT CONSTITUTE THE RELEASE OF  
 ANY PROPRIETARY RIGHTS THEREIN. PERMISSION TO REPRODUCE  
 THIS INFORMATION OR THE PRODUCTS DISCLOSED HEREIN  
 MUST BE OBTAINED IN WRITING FROM COFAN INC.

NOTES?

1. INSERT THE PIN IN PLACE, MUST BE INSTALLED TIGHT.
2. G.W APPROX 8.9G/PCS.
3.  $\triangle$  IS CRITICAL INSPECTION POINT. NUMBERING IN TRIANGLE IS TO BE USED FOR CROSS REFERENCE OF INSPECTION REPORT TO DRAWING DIMENSION OR FEATURE.

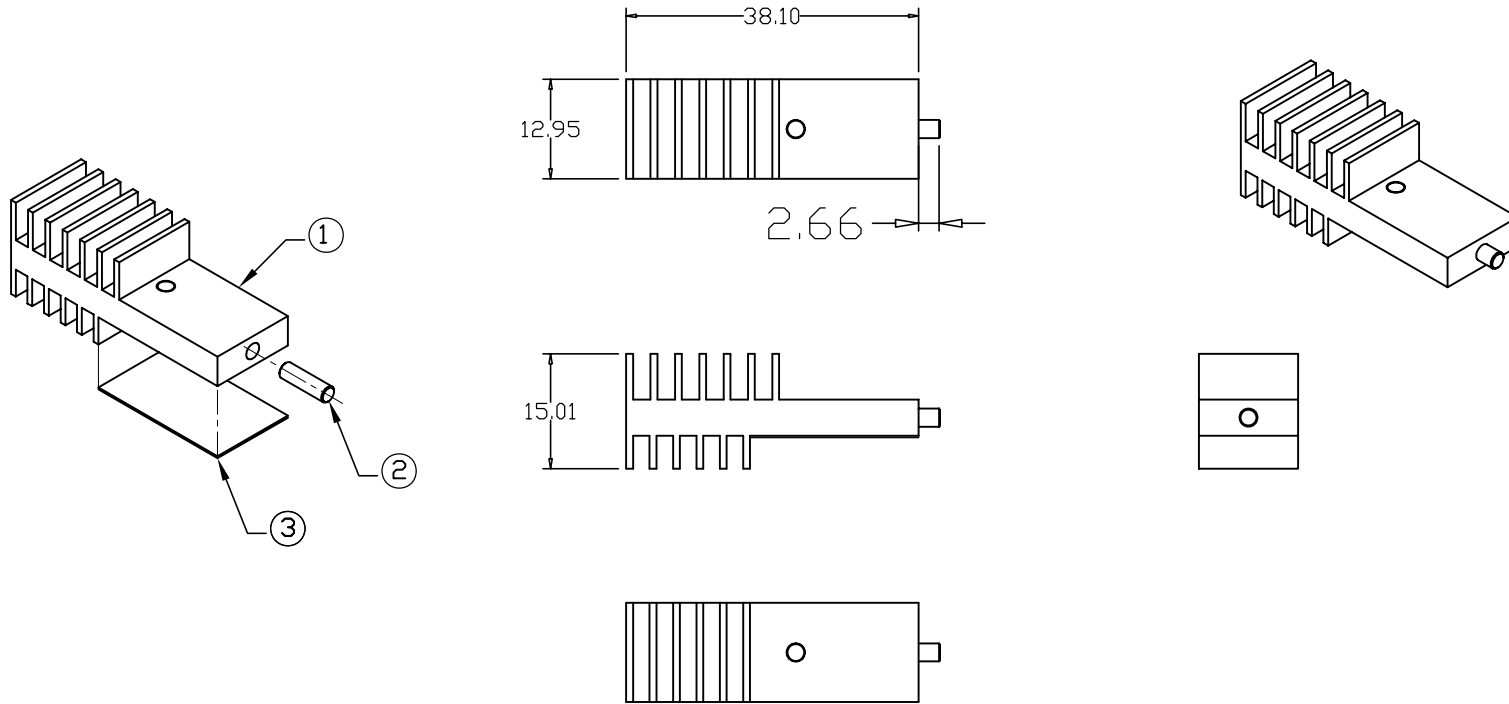

RoHS  
 Compliant  
 2002/95/EC

③	70-1050	CHOMERICS 60-12-D393-T500	1PCS
②	50-1119	PIN,CARBON STEEL,TIN PLATED	1PCS
①	20-1355	HEATSINK,AL6063/BLACK ANODIZE	1PCS
NO.	P/N	DESCRIPTION	QTY

DO NOT SCALE DRAWING  
 UNLESS OTHERWISE SPECIFIED  
 DIMENSIONS ARE IN MILLIMETRE  
 TOLERANCES ARE:  
 1 PLACE .X  $\pm 0.25$   
 2 PLACE .XX  $\pm 0.13$   
 3 PLACE .XXX  $\pm 0.05$   
 ANGLES EXCEPT 90°  $\pm 0.5^\circ$   
 MAXIMUM SURFACE ROUGHNESS 3.1  $\sqrt{\text{ }}$

MATERIAL:	①	CUSTOMER DRAWING NUMBER:	---		
FINISH:	②	CUSTOMER PART NUMBER:	NAME: COFAN USA 1400 FULTON PL. UNIT A FREMONT CA 94539		
DRAWN BY:	Bob.G	COFAN DRAWING NUMBER:	SCALE:	CUS REV:	COF REV:
APPR BY:		30-1162	1:1	01	01
		COFAN PART NUMBER:	SHEET:	DATE DRAWN:	
		30-1162	1 OF 1	Jul-08-2006	